



Fryer Oil Tank Catalog

AnGen International Inc.

6411 Ory Bridge Court
Lisle, IL 60532 USA
Phone: (630) 544-8208
Fax: (630) 416-4371
www.angenintl.com

O001 (Top)

Measurement (mm): 627.0*394.0

Material: SUS304

Unit Net Weight (kg): 14.58

Total Package Weight (kg): 22.00



O001 (Bottom)

Measurement (mm): 627.0*394.0

Material: SUS304

Unit Net Weight (kg): 14.58

Total Package Weight (kg): 22.00



O002 (Top)

Measurement (mm): 627.0*394.0

Material: SUS304

Unit Net Weight (kg): 18.64

Total Package Weight (kg): 24.00



O002 (Bottom)

Measurement (mm): 627.0*394.0

Material: SUS304

Unit Net Weight (kg): 18.64

Total Package Weight (kg): 24.00

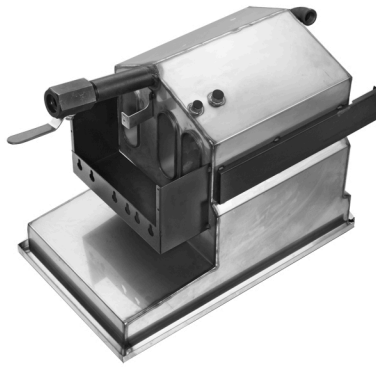

O003 (Top)

Measurement (mm): 700*455.3

Material: SUS304

Unit Net Weight (kg): 20.53

Total Package Weight (kg): 26.00



O003 (Bottom)

Measurement (mm): 700*455.3

Material: SUS304

Unit Net Weight (kg): 20.53

Total Package Weight (kg): 26.00



O004 (Top)

Measurement (mm): 730.3×495.3

Material: SUS304

Unit Net Weight (kg): 22.46

Total Package Weight (kg): 28.00



O004 (Bottom)

Measurement (mm): 730.3×495.3

Material: SUS304

Unit Net Weight (kg): 22.46

Total Package Weight (kg): 28.00

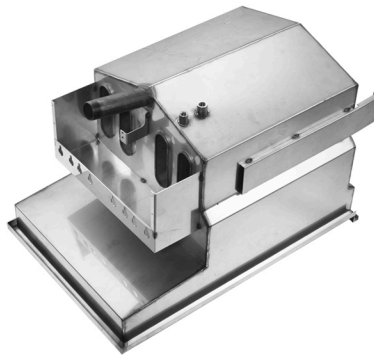

O005

Measurement (mm): 680.5*412.3

Material: SUS304

Unit Net Weight (kg): 26.20

Total Package Weight (kg): 32.00



O006 (Top)

Measurement (mm): 572.0*304.4

Material: SUS304

Unit Net Weight (kg): 8.30

Total Package Weight (kg): 9.30



O006 (Bottom)

Measurement (mm): 572.0*304.4

Material: SUS304

Unit Net Weight (kg): 8.30

Total Package Weight (kg): 9.30

